

**EN** Start by removing the seat, insert the passenger handle underneath the aluminium cross bar(1) , tighten the 4 screws as seen in the picture to attach the passenger grip to the frame of the bike.

NB: Model NIneT: Use the 2 included screws  
Model Scrambler/Urban GS: Use the 4 original screws

.....

**IT** Iniziare rimuovendo la sella, inserire la maniglia passeggero sotto la barra trasversale di alluminio ( 1 ) , serrare le 4 viti come mostrato in figura per collegare la maniglia passeggero al telaio della moto .

NB: Modello NIneT: Usare 2 viti in dotazione  
Modello Scrambler/Urban GS: Usare le 4 viti originali

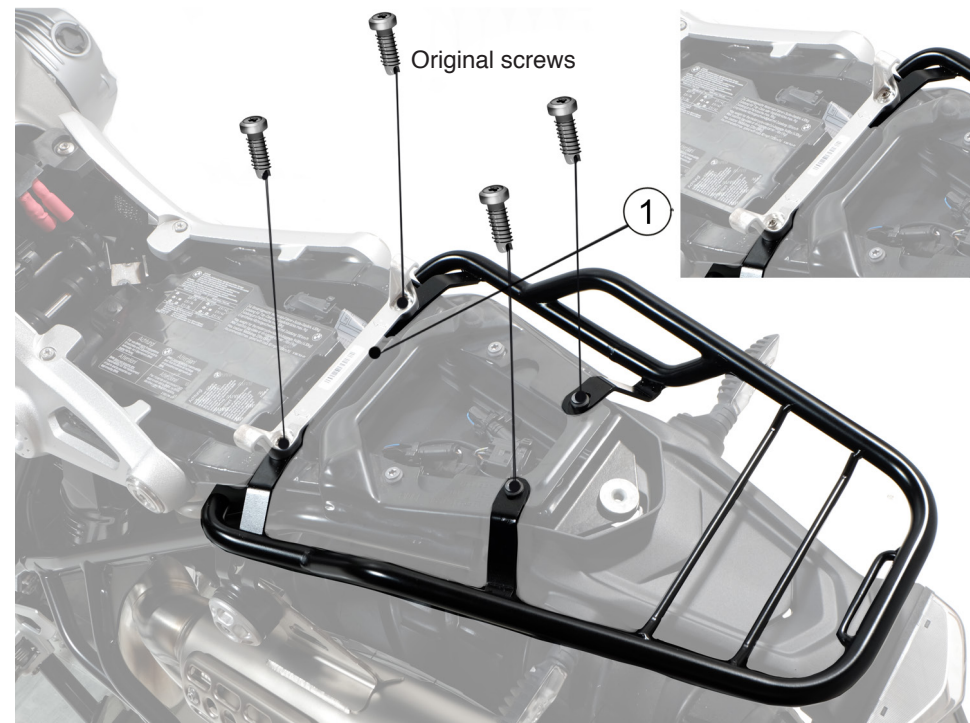

**EN** Start by removing the seat, insert the passenger handle underneath the aluminium cross bar(1) , tighten the 4 screws as seen in the picture to attach the passenger grip to the frame of the bike.

NB: Model NIneT: Use the 2 included screws  
Model Scrambler/Urban GS: Use the 4 original screws

.....

**IT** Iniziare rimuovendo la sella, inserire la maniglia passeggero sotto la barra trasversale di alluminio ( 1 ) , serrare le 4 viti come mostrato in figura per collegare la maniglia passeggero al telaio della moto .

NB: Modello NIneT: Usare 2 viti in dotazione  
Modello Scrambler/Urban GS: Usare le 4 viti originali